

Ersatzteile Spare parts

Metallbandsäge
Metal band saw

- OPTI** saw[®]
S 275N Artikel Nr. *Item no.* 3300260
- OPTI** saw[®]
S 275NV Artikel Nr. *Item no.* 3300265

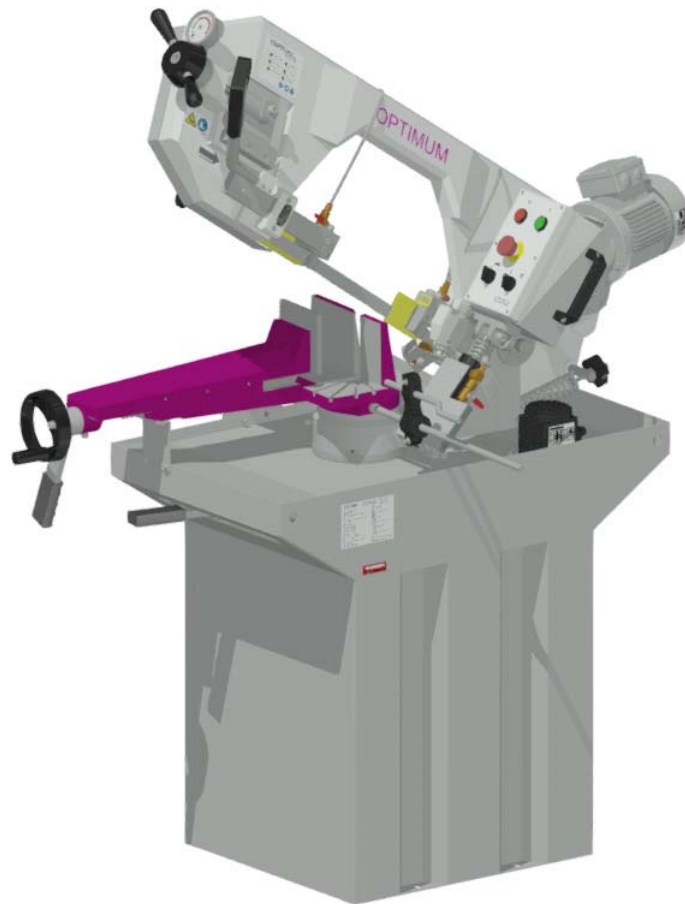

1 Ersatzteile - Spare parts

1.1 Ersatzteilbestellung - Ordering spare parts

Bitte geben Sie folgendes an - Please indicate the following:

- Seriennummer - Serial No.
- Maschinenbezeichnung - Machines name
- Herstellungsdatum - Date of manufacture
- Artikelnummer - Article no.

Die Artikelnummer befindet sich in der Ersatzteilliste. *The article no. is located in the spare parts list.* Die Seriennummer befindet sich am Typschild. *The serial no. is on the rating plate.*

1.2 Hotline Ersatzteile - Spare parts Hotline



+49 (0) 951-96555 -118

ersatzteile@stuermer-maschinen.de



1.3 Service Hotline



+49 (0) 951-96555 -100

service@stuermer-maschinen.de



1.4 Ersatzteilzeichnungen - Spare part drawings

A Bandsäge 1-3 - Band saw 1-3

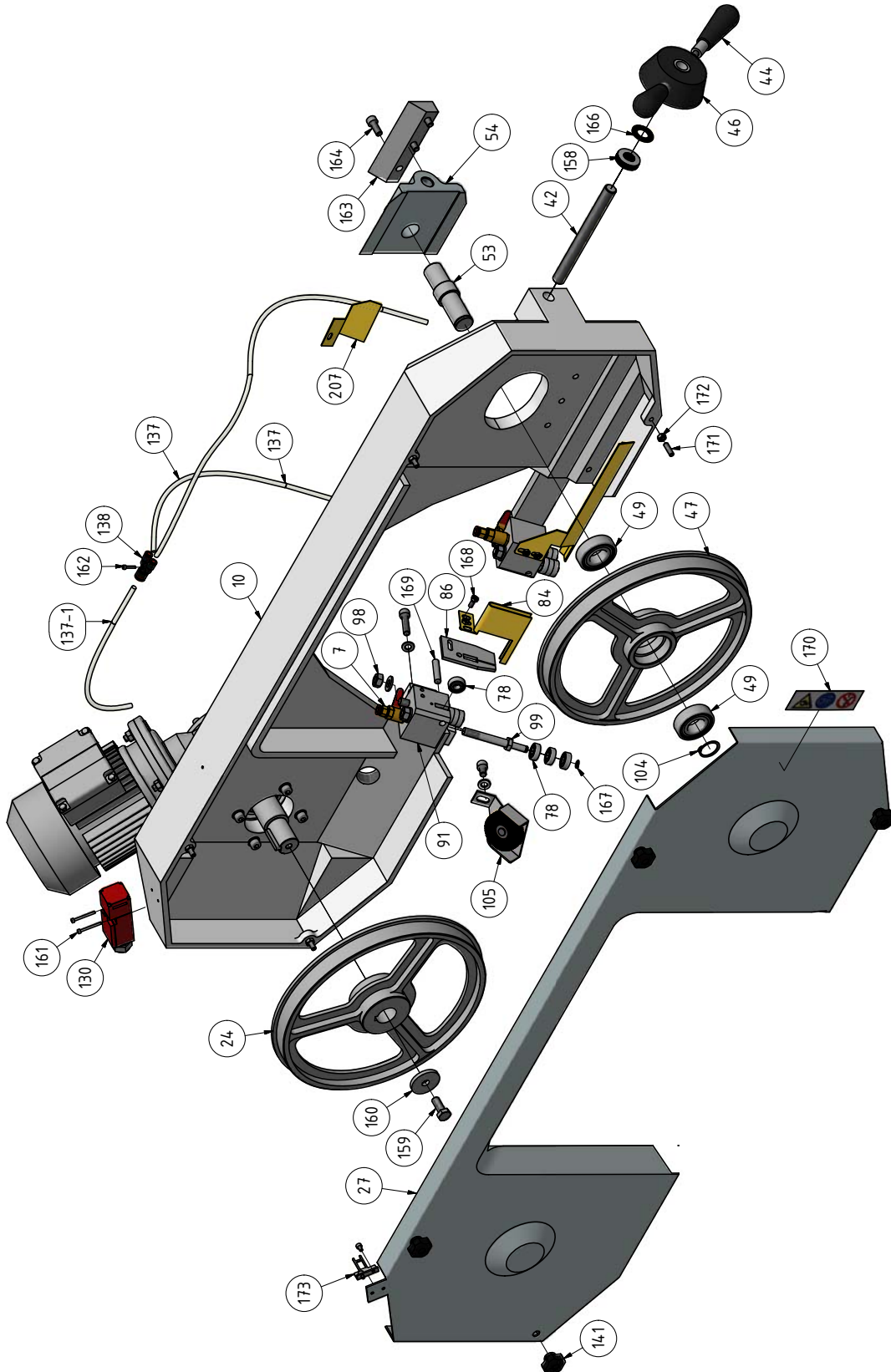

Img.1-1: Bandsäge 1-3 - Band saw 1-3

S275N_S275NV_parts.fm

B Bandsäge 2-3 - Band saw 2-3

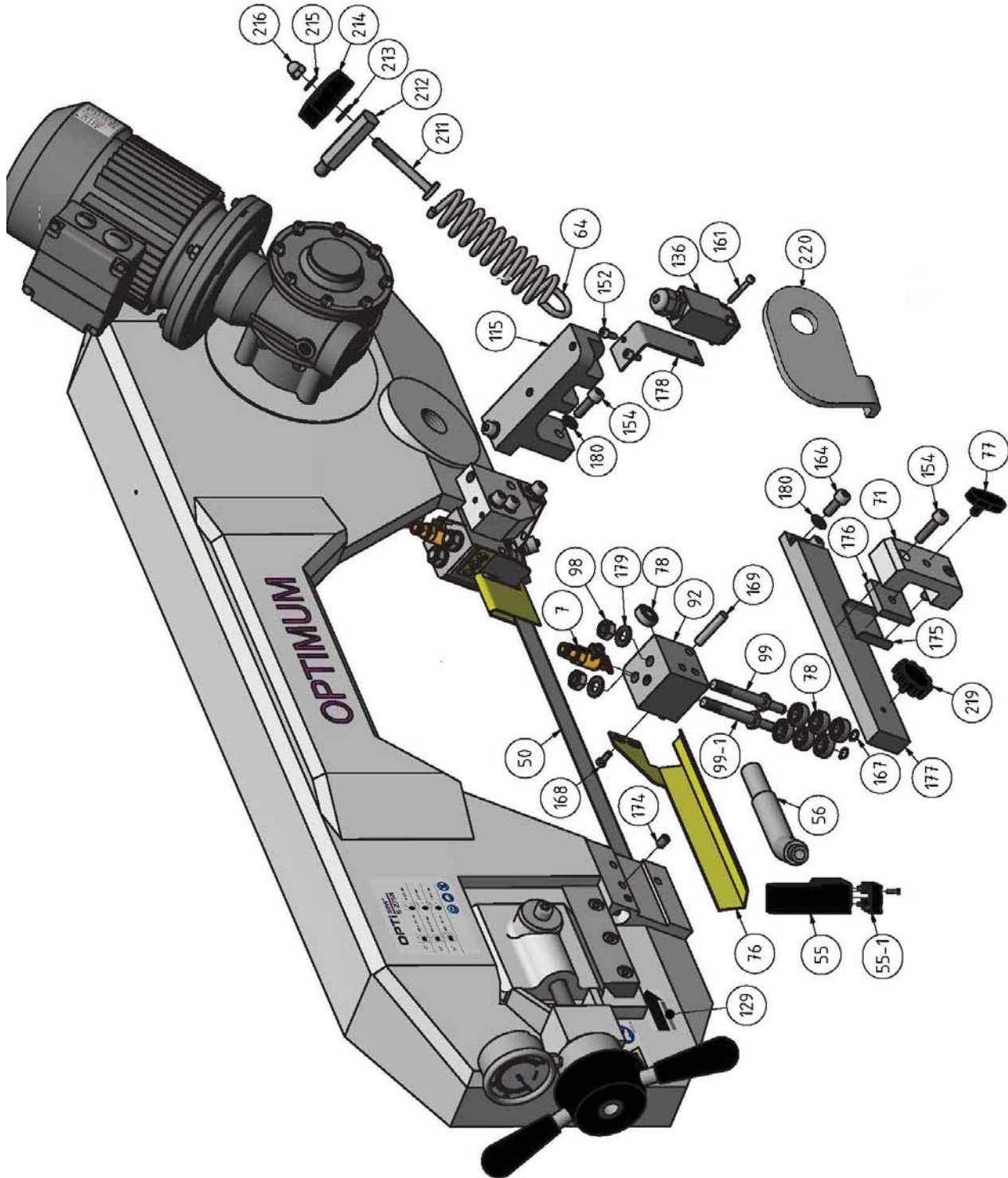

Img.1-2: Bandsäge 2-3 - Band saw 2-3

S275N_S275NV_parts.fm

C Bandsäge 3-3 - Band saw 3-3

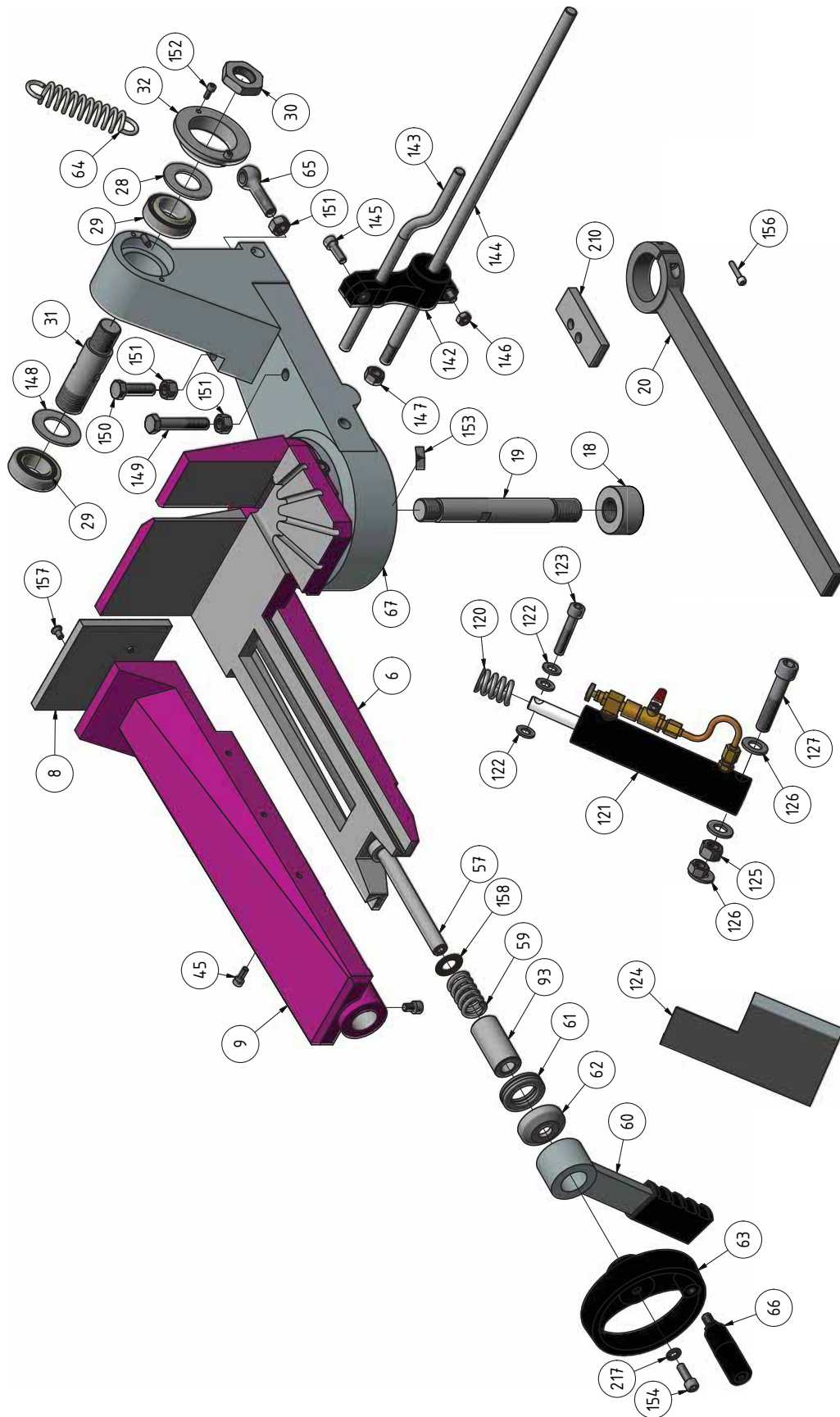

Img. 1-3: Bandsäge 3-3 - Band saw 3-3

S275N_S275NV_parts.fm

E Maschinenunterbau - Substructure - V1

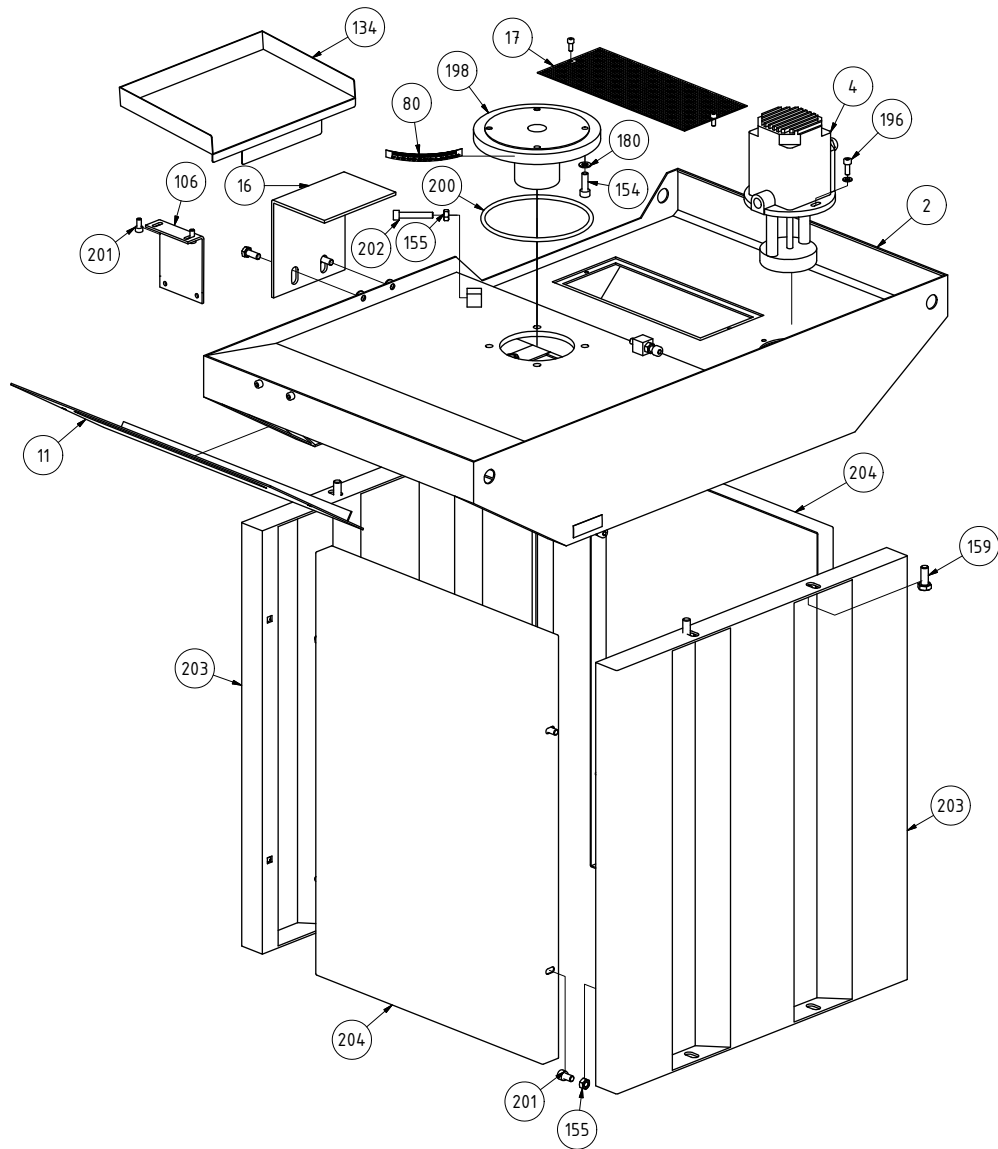

Img. 1-5: Maschinenunterbau - Machine substructure

F Maschinenunterbau - Substructure - V2

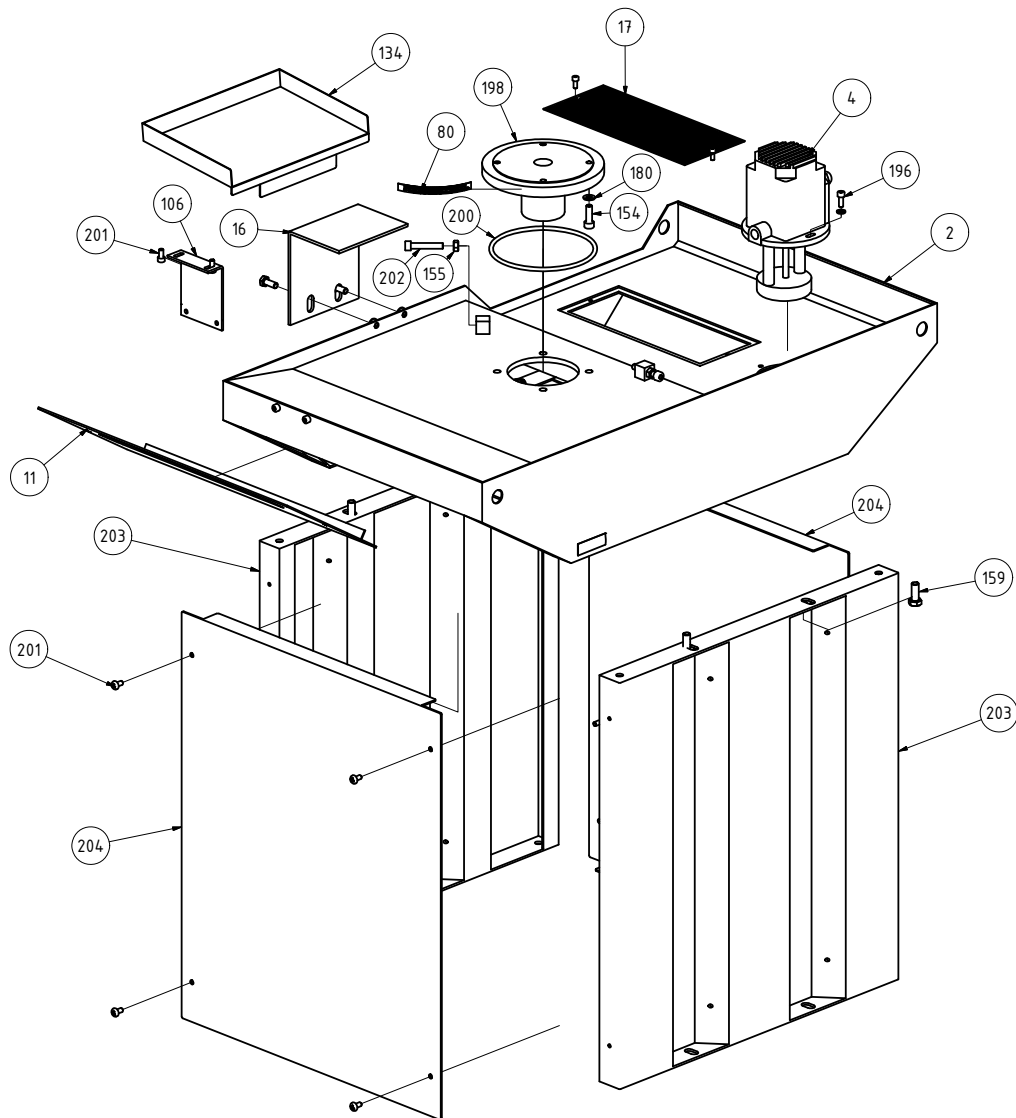

Img. 1-6: Maschinenunterbau - Machine substructure

G Schaltkasten - Electrical box - S275N

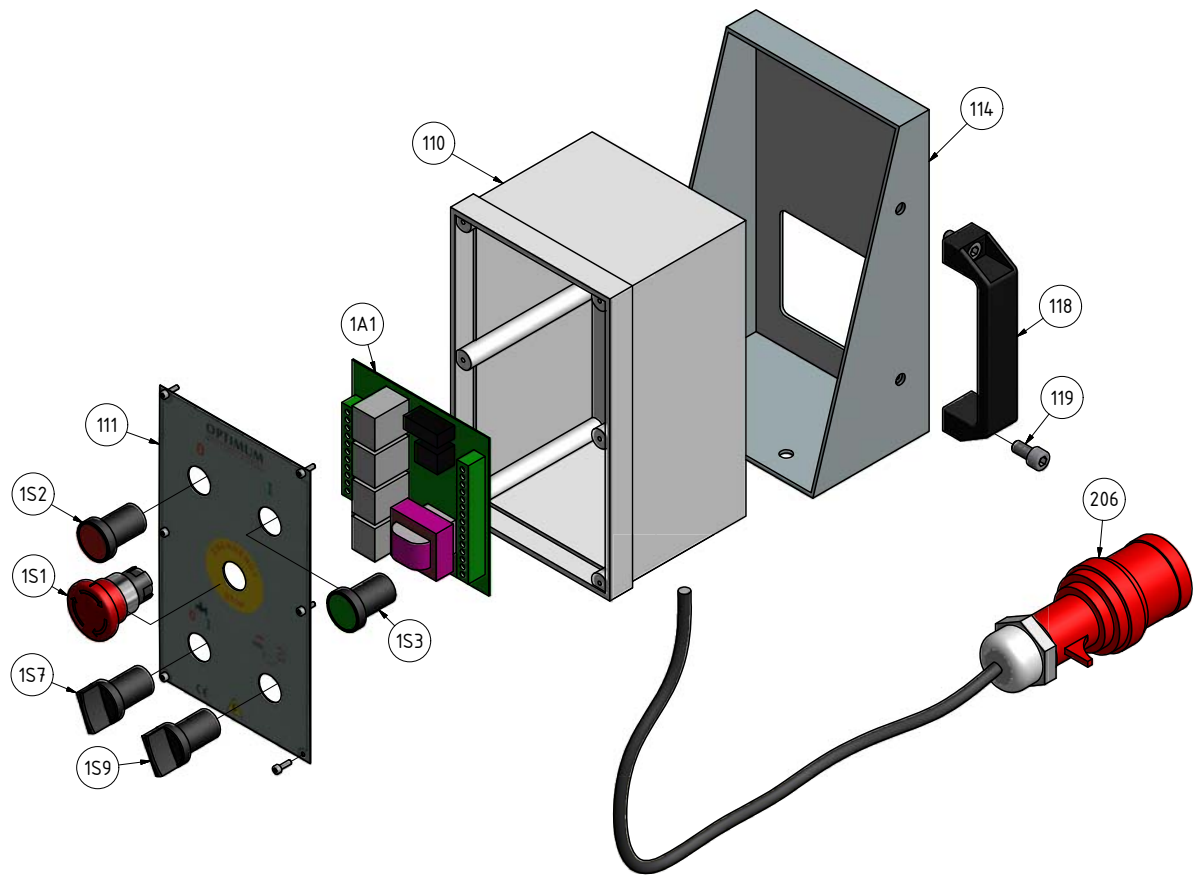

Img.1-7: Schaltkasten - Electrical box

H Schaltkasten - Electrical box - S275NV

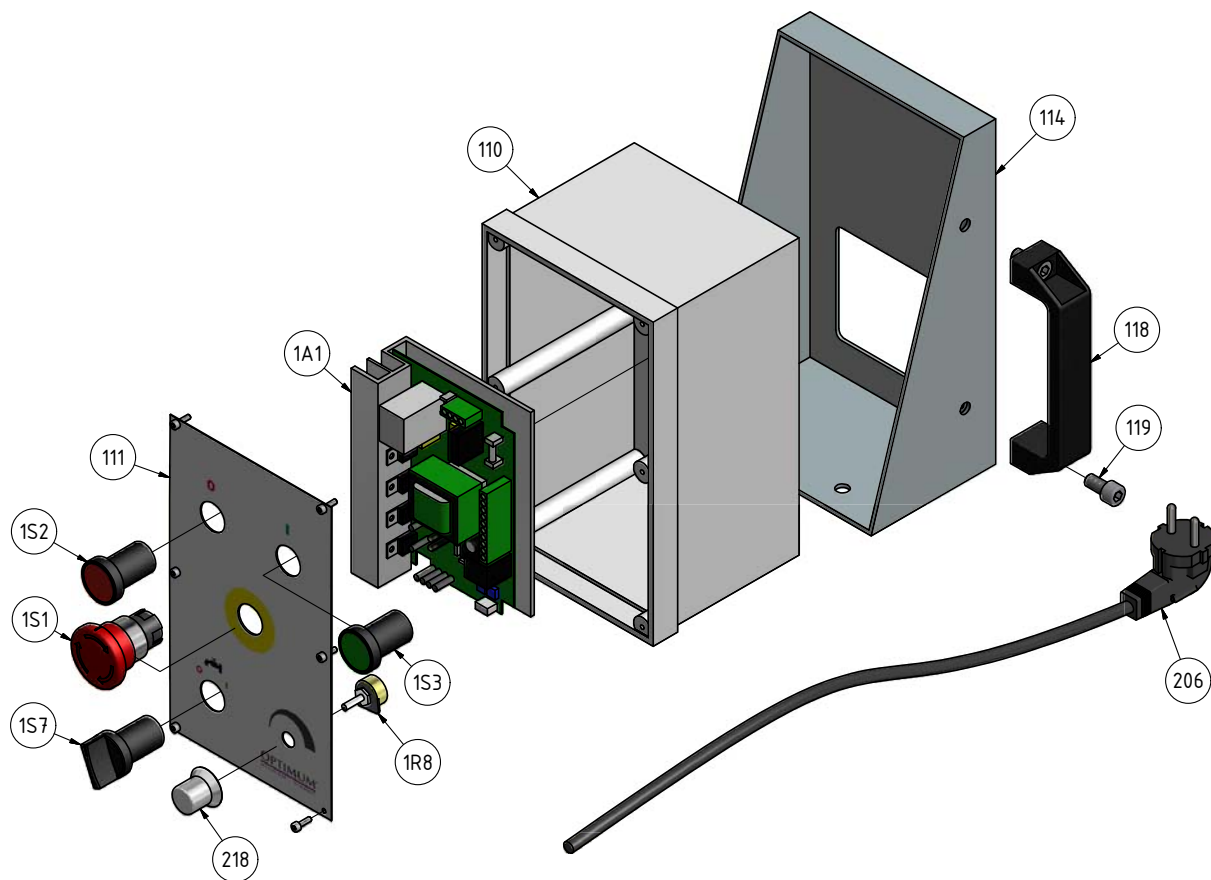

Img. 1-8: Schaltkasten - Electrical box

1.5 Schaltplan - Wiring diagram 400V - S275N - Einkanalig - Single channel

S275N_S275NV_parts.fm

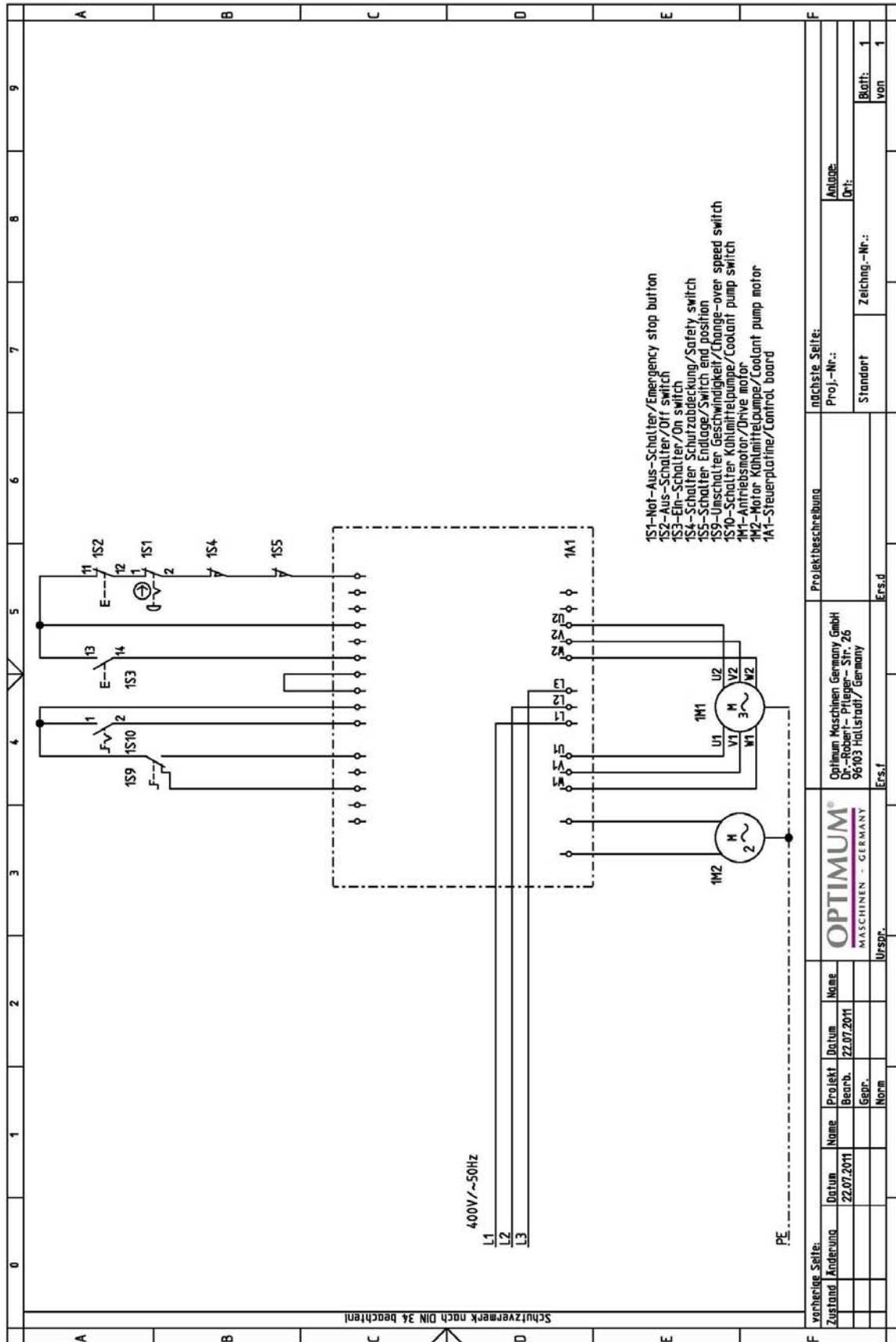

1.6 Schaltplan - Wiring diagram 400V - S275N - Zweikanalig - Double channel

J

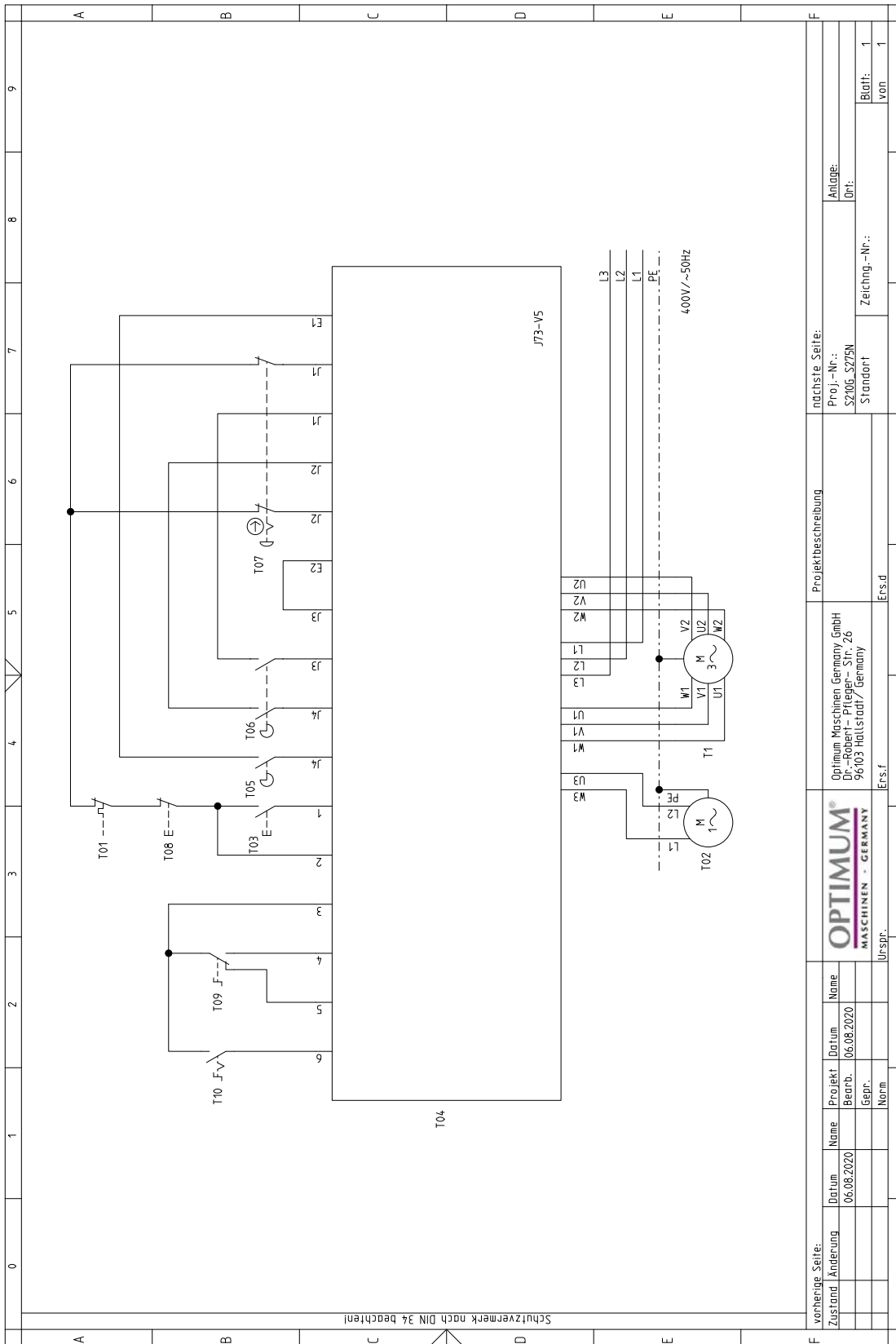

vorherige Seite:		Projektbeschreibung		nächste Seite:	
Zustand	Änderung	Optimum Maschinen GmbH Dr.-Robert-Pfleger-Str. 26 96103 Hallstadt / Germany		Proj.-Nr.:	S2106-S275N
		Ers.f		Standort	Zeichn.-Nr.:
		Urspr.		Blatt:	1
		Ers.d		von	1

1.7 Schaltplan - Wiring diagram - S275NV

K

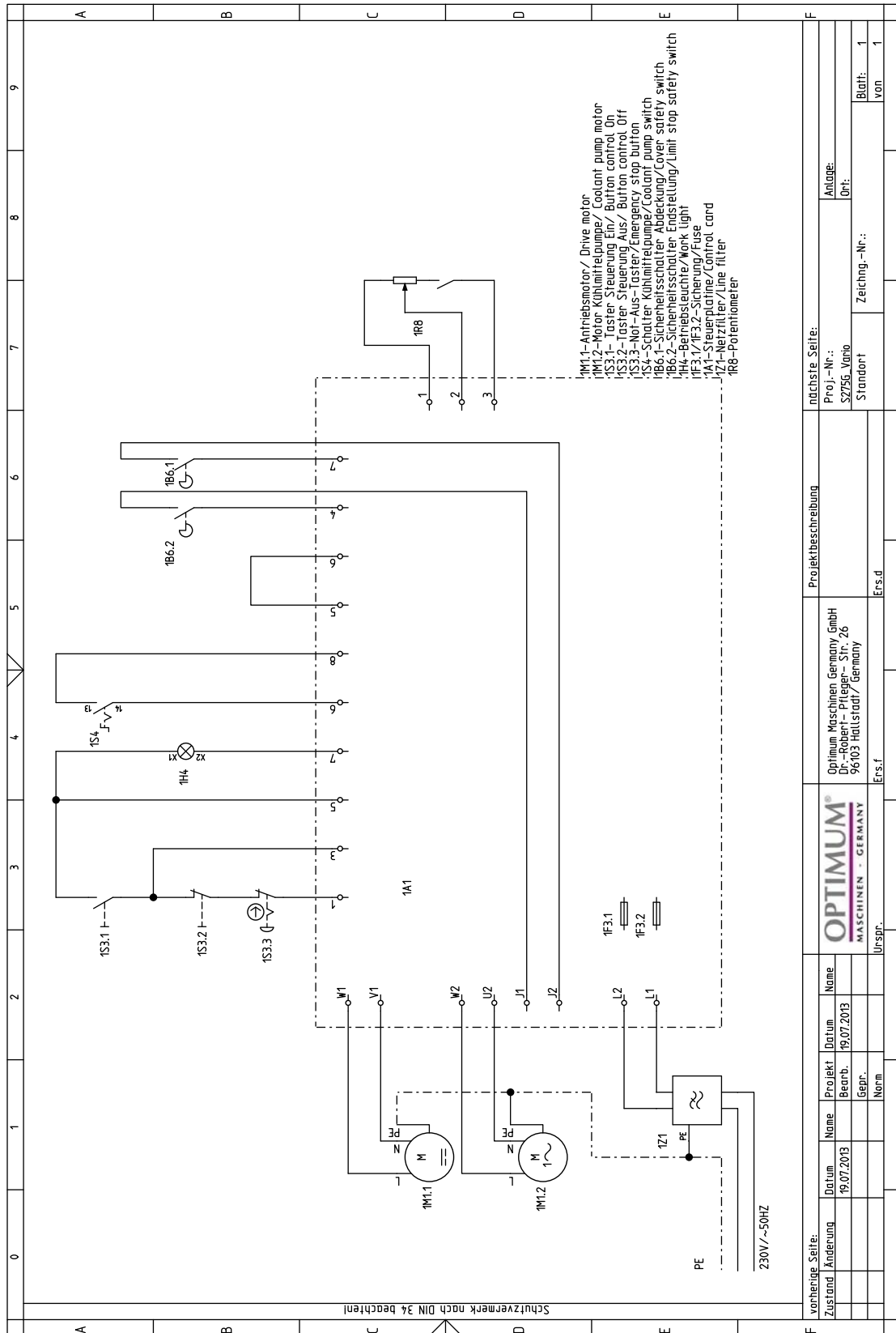

S275N_S275NV_parts.fm

Ersatzteilliste - Spare parts list - S275N, S275NV

Pos.	Bezeichnung	Description	Menge	Grösse	Artikelnummer
			Qty.	Size	Item no.
2	Maschinengestell	Machine casing	1		0330027502
4	Kühlmittelpumpe	Cooling pump	1	230V	0330014555
				400V	0330021004
6	Feste Backe	Fixed jaw	1		0330027506
7	Kühlmittelhahn	Cooling valve	1		0330021007
8	Schraubstockbacken	Vice jaw	1		0330027508
9	Bewegliche Backe	Moveable jaw	1		0330027509
10	Sägebügel	Saw bow	1		0330027510
11	Verkleidungsblech	Lining plate	1		0330027511
16	Stützbügel	Support	1		0330021016
17	Kühlmittelsieb	Filter	1		0330027517
18	Distanzscheibe	Spacer washer	1		0330021018
19	Bolzen	Bolt	1		0330027519
20	Feststellhebel	Locking lever	1		0330021020
22	Passfeder	Key	1	DIN6885/8x7x36	0330021022
23	Lager	Bearing	1	6207	0406207
24	Angetriebene Bandführungsrolle	Driven belt guide roller	1		0330027524
26	Antriebswelle	Drive shaft	1		0330027526
27	Schutzabdeckung Sägebügel	Protective cover for saw bow	1		0330027527
28	Scheibe	Washer	2		0330021028
29	Lager	Bearing	2	32006.2R	04032006
30	Nutmutter	Groove nut	1	M30	0330021030
31	Drehzapfen	Trunnion	1		0330021031
32	Lagerabdeckung	Bearing cover	1		0330021032
34	Passfeder	Key	1	DIN6885/8x7x25	0330021034
35	Schneckengetriebe	Worm Gear	1	V1.0 without additional 6207 2Z	0330027535
35	Schneckengetriebe	Worm Gear	1	V1.1 with bearing 6207 2Z	03300275351
35-1	Simmerring Getriebe	Shaft seal helical gear	1	TC 35/70/10 F542	041355010
35-2	Simmerring Getriebe	Shaft seal helical gear	1	25/40/7	04125407
36	Motor	Motor	1	S275N	0330027536
36	Motor	Motor	1	S275NV	0330027836
42	Gewindestange	Threaded rod	1		0330027542
44	Handradgriff	Hand wheel grip	2		0330021044
45	Innensechskantschraube	Socket head screw	1	GB70-85/M5x16	0330021045
46	Nabe	Hub	1		0330021046
47	Bandführungsrolle	Un-driven belt guide roller	1		0330027547
49	Lager	Bearing	2	6205 2Z	0406205.2R
53	Welle	Shaft	1		0330027553
54	Führungsblock	Guide block	1		0330027554
55	Handgriff	Handgrip	1		0330021055
56	Handgriffverlängerung	Handgrip extension	1		0330021056
57	Spindel	Spindle	1		0330021057
59	Feder	Spring	1		0330021059
60	Spannhebel	Tension lever	1		0330021060
61	Lager	Bearing	1	51106.2R	04051106
62	Lagerabdeckung	Bearing cover	1		0330021062
63	Handrad	Hand wheel	1		0330021063
64	Feder	Spring	1	ab Bj. 06/2012	0330027564
64A	Feder	Spring	1	bis Bj. 06/2012	030027564A
65	Ösenschraube	Eyelet bolt	1		0330021065
66	Griff Handrad	Handle grip	1		0330021066
67	Lagerbock	Bearing support	1		0330027567
68	Bolzen	Bolt	1		0330027568
71	Block	Block	1		0330027571
77	Griff	Hand grip	1		0330021077
78	Lager	Bearing	11	6082Z	040608ZZ
80	Skala	Scale	1	ab Bj. 10/2009	0330027581
80A	Skala	Scale	1	bis Bj. 10/2009	0330027581A
84	rechte Schutzabdeckung	Protection cover right	1		0330027584
86	Halter Schutzabdeckung	Holder protection cover	1		0330027586
91	feststehende Bandsägeführung	Fixed belt saw guide	1		0330027591
92	verschiebbare Bandsägeführung	Adjustable belt saw guide	1		0330027592
93	Distanzhülse	Spacer	1		0330021093
98	Sechskantmutter	Hexagonal nut	1	M 10	
99	Führungsdrehzapfen Sägeband	Saw belt guide trunnion	2	exzentrisch / eccen- tric	0330027599

S275N_S275NV_parts.fm

Ersatzteilliste - Spare parts list - S275N, S275NV

Pos.	Bezeichnung	Description	Menge	Grösse	Artikelnummer
			Qty.	Size	Item no.
99-1	Führungsdrehzapfen Sägeband	Saw belt guide trunnion	2	zylindrisch/ cilindrical	03300275991
104	Sicherungsring	Safety ring	1	DIN471/25x1,2	042SR25W
105	Sägebandbürste	Metal belt brush	1		03300275105
106	Stützblech	Support plate	1		03300260106
110	Schalterkasten Bedienschalter	Distribution box	1		03300275110
111	Schalter Platte	Switch plate	1	S275N	03300275111
111	Schalter Platte	Switch plate	1	S275NV	03300278111
114	Halter Schaltkasten	Holder distribution box	1		03300210114
115	Halter Zylinder	Holder cylinder	1	ab 05/2008	03300275115
115A	Halter Zylinder	Holder cylinder	1	bis 05/2008	03300275115A
118	Handgriff	Knob	1		03300210118
119	Innensechskantschraube	Hex. socket head cap screw	2		
120	Feder	Spring	1		03300210120
121	Hydraulikzylinder	Hydraulic cylinder	1		03300275121
122	Scheibe	Washer	1		
123	Innensechskantschraube	Hex. socket head cap screw	1		0330021090
124	Schutzabdeckung	Protective cover	1		03300210124
125	Sechskantmutter	Hex.Nut	1		
126	Scheibe	Washer	1		
127	Innensechskantschraube	Hex. socket head cap screw	1		03300275127
129	Platte	Plate	1		03300210129
130	Endschalter/ Abdeckung	Limit switch/ cover	1		0329035017
131	Motorlüfterdeckel	Motor flywheel cover	1		03300275131
132	Lüfterrad	Motor flywheel	1	S275N	03300275132
132	Lüfterrad	Motor flywheel	1	S275NV	03300278132
134	Auffangblech	Sheet	1		03300210134
136	Endlagenschalter	Limit switch	1		03300210136
137	Kühlmittelschlauch	Coolant hose	1	SET	0329029081
138	Schlauchverbinder/-verteiler	Hose fitting/ distributor	1		03300210138
141	Klemmmutter	Clamping nut	4	M6	03300210141
142	Halter	Holder	1		03300210142
143	Stange A	Rod A	1		03300210143
144	Stange B	Rod B	1		03300210144
145	Innensechskantschraube	Socket head screw	2	GB70-75/M8x25	
146	Sechskantmutter	Hexagonal nut	2	ISO 4031/M8	
147	Sechskantmutter	Hexagonal nut	1	ISO 4031/M12	
148	Scheibe	Washer	1		
149	Sechskantschraube	Counter sunk screw	1	ISO 4014/M12x65	
150	Sechskantschraube	Counter sunk screw	1	ISO 4014/M12x40	
151	Sechskantmutter	Hexagonal nut	2	ISO 4032/M12	
152	Innensechskantschraube	Socket head screw	2	GB 70-85/5x12	
153	Zeiger	Indicator	1		03300210153
154	Innensechskantschraube	Socket head screw	1	GB 70-85/8x25	
155	Sechskantmutter	Hexagonal nut	1	ISO 4032/M8	
156	Innensechskantschraube	Hexagonal nut	1	GB 70-85/5x25	
157	Senkschraube	Counter sunk screw	2	ISO 10642/M6x12	
158	Lager	Bearing	1	AXK 1730	040AXK1730
159	Sechskantschraube	Hexagon screw	1	ISO 4014/M10x25	
160	Scheibe	Washer	2		03300210160
161	Innensechskantschraube	Socket head screw	2	GB 70-85/3x30	
162	Innensechskantschraube	Socket head screw	2	GB 70-85/3x16	
163	Platte	Plate	1		03300275163
164	Innensechskantschraube	Socket head screw	1	GB 70-85/8x20	
165	Zeiger	Indicator	1		0330026310
166	Federscheibe	Washer	1		03300210166
167	Sicherungsring	Retaining ring	2	DIN 471/8x0,8	042SR8W
168	Sechskantschraube	Hexagon screw	4	GB29.2-88/M5x12	
169	Zylinderstift	Cylinder pin	1	GB119-86/8x40	
170	Infolabel	Info label	1		03300210170
171	Gewindestift	Grub screw	4		
172	Sechskantmutter	Hexagon nut	4	ISO 4032/M6	
173	Druckplatte	Pressure plate	1		0460054
174	Gewindestift	Grub screw	3	GB80-85/M8x12	
175	Platte	Plate	1		03300275175
176	Druckplatte	Pressure plate	1		03300275176
177	Führungsplatte	Guide plate	1		03300275177
178	Winkel	Angle	1		
179	Scheibe	Washer	2	DIN125/10	

S275N_S275NV_parts.fm

Ersatzteilliste - Spare parts list - S275N, S275NV

Pos.	Bezeichnung	Description	Menge	Grösse	Artikelnummer
			Qty.	Size	Item no.
180	Scheibe	Washer	2	DIN125/8	
182	Flansch	Flange	1	ab Bj. 2006	03300275182
182A	Flansch	Flange	1	bis Bj. 2005	03300275182A
183	Rillenkugellager	Ball bearing	1	6005	0406005
184	Schnecke	Worm	1		03300275184
185	Rillenkugellager	Ball bearing	1	6203	0406203
186	Schneckenrad	Worm gear	1		03300275186
187	Rillenkugellager	Ball bearing	1	6205	0406205
188	Dichtung	Seal	2		03300275188
189	Lagerdeckel	Bearing cover	1	V1.0 without additional 6207 2Z	03300275189
189	Lagerdeckel	Bearing cover	1	V1.1 for bearing 6207 2Z	033002751891
190	Passfeder	Fitting key	1	DIN6885/5x5x22	
191	Innensechskantschraube	Socket head screw	6	GB 70-85/6x16	
192	Sechskantschraube	Hexagon nut	4	ISO4017/M8x30	
193	Sicherungsring	Retaining ring	1	DIN472/40x1,75	042SR40I
194	Stopfen	Plug	1		041408
195	Verschlusschraube	Plug screw	2		03300210195
196	Innensechskantschraube	Socket head screw	8	GB 70-85/M6x16	
197	Deckel	Cover	1		
198	Aufnahme	Collet	1		03300210198
199	Infolabel	Info label	1		
200	O-Ring	O-Ring	1	GB3452/140x5,3	03300210200
201	Innensechskantschraube	Socket head screw	8	GB 70-85/8x14	
	Schraube	Screw	8	M6	
202	Innensechskantschraube	Socket head screw	8	GB 70-85/8x45	
203	Seitenwand links/rechts	Side panel right/left	2	V1	03300210203
	Seitenwand links/rechts	Side panel right/left	2	V2	03300210203V2
204	Seitenwand vorne/hinten	Side panel front/back	2	V1	03300210204
	Seitenwand vorne/hinten	Side panel front/back	2	V2	03300210204V2
205	Infolabel	Info label	1		
206	Anschlusstecker	Connector plug	1	400V	
			1	230V	0342025107
210	Platte Baujahr bis 2007	Plate year of manufacture to 2007	1		
211	Schraube	Screw	1		
212	Bolzen	Bolt	1		03300210212
213	Scheibe	Washer	1		
214	Sterngriff	Star grip	1		
215	Scheibe	Washer	1		
216	Hutmutter	Acorn nut	1		
217	Scheibe	Washer	1		
218	Knopf	Knob	1		
219	Klemmschraube	Clamping screw	1		03300260219
220	Platte	Plate	1		03300210218
221	Lager	Bearing	1	6207 2Z	04062072Z
1M1	Antriebsmotor	Drive motor	1	S275N	0330027536
1M1.1	Antriebsmotor	Drive motor	1	S275NV	0330027836
1M2	Motor Kühlmittelpumpe	Coolant pump motor	1	S275N	0330021004
1M1.2	Motor Kühlmittelpumpe	Coolant pump motor	1	S275NV	0330014555
1S1	Not-Halt Schalter	Emergency stop button	1	S275N	0460049
1S2	Taster "AUS"	Button "OFF"	1	S275N	0460001
1S3	Taster "EIN"	Button "ON"	1	S275N	0460052
1S3.1	Taster Steuerung Ein	Button control On	1	S275NV	0330013169
1S3.2	Taster Steuerung Aus	Button control Off	1	S275NV	0460001
1S3.3	Not-Halt-Taster	Emergency stop button	1	S275NV	0460049
1S4	Schalter Abdeckung	Switch cover	1	S275N	
1B6.1	Sicherheitsschalter Abdeckung	Cover safety switch	1	S275NV	0460054
1S4	Schalter Kühlmittelpumpe	Coolant pump switch	1	S275NV	0322792
1S5	Endlagenschalter	End position switch	1	S275N	
1B6.2	Sicherheitsschalter Endstellung	Limit stop safety switch	1	S275NV	0329035017
1S9	Schalter Geschwindigkeit	Speed selector switch	1	S275N	0322791
1S10	Schalter Kühlmittelpumpe	Coolant pump switch	1	S275N	0322792
Box2	Klemmkasten Motor	Box motor	1	S275N	
1H4	Betriebsleuchte	Work light	1	S275NV	0330013169
1A1	Steuerplatine mit Trafo	Control board with transformer	1	S275N	03300275LE
1F3.1	Sicherung	Fuse	1	S275NV	033002781F3
1F3.2			1		
1A1	Steuerplatine	Control card	1	S275NV	033001451A1

S275N_S275NV_parts.fm

Ersatzteilliste - Spare parts list - S275N, S275NV					
Pos.	Bezeichnung	Description	Menge	Grösse	Artikelnummer
			Qty.	Size	Item no.
1R8	Potentiometer	Potentiometer	1	S275NV	033001451R8
1Z1	Netzfilter	Line filter	1	S275NV	
-	Schlauchanschluss Kühlmittelpumpe	Connector coolant pump	1	S275N	033002104-1
-	Bandführung fest kplt.	Fix belt guide complete	1	S275N	0330027591CPL
-	Bandführung beweglich kplt.	Adjustable belt guide complete	1	S275N	0330027592CPL
Pos.	Bezeichnung	Designation	Menge	Grösse	Artikelnummer
			Qty.	Size	Item no.
Schaltplan S275N Zweikanalig - Wiring diagram S275N Double channel					
T10	Schalter Kühlmittelpumpe	Coolant pump switch	1	S275N	0322792
T09	Schalter Geschwindigkeit	Speed selector switch	1	S275N	0322791
T01	Temperatursensor Antriebsmotor	Motor temperature sensor	1	S275N	03300260T01
T03	Taster "EIN"	Button "ON"	1	S275N	0460052
T04	Steuerplatine	Control board	1	S275N double channel	033002601T3
T08	Taster "AUS"	Button "OFF"	1	S275N	0460001
1M3	Motor Kühlmittelpumpe	Coolant pump motor	1	S275N	0330021004
T06	Schalter Abdeckung	Cover switch	1	S275N	03300260T06
T05	Endlagenschalter	End position switch	1	S275N	03300260T05
1M4	Antriebsmotor	Drive motor	1	S275N	0330027536
T07	Not-Halt Schalter	Emergency stop button	1	S275N	0460049

K S275N ; S210G - Special voltage - single phase - one speed - 230V

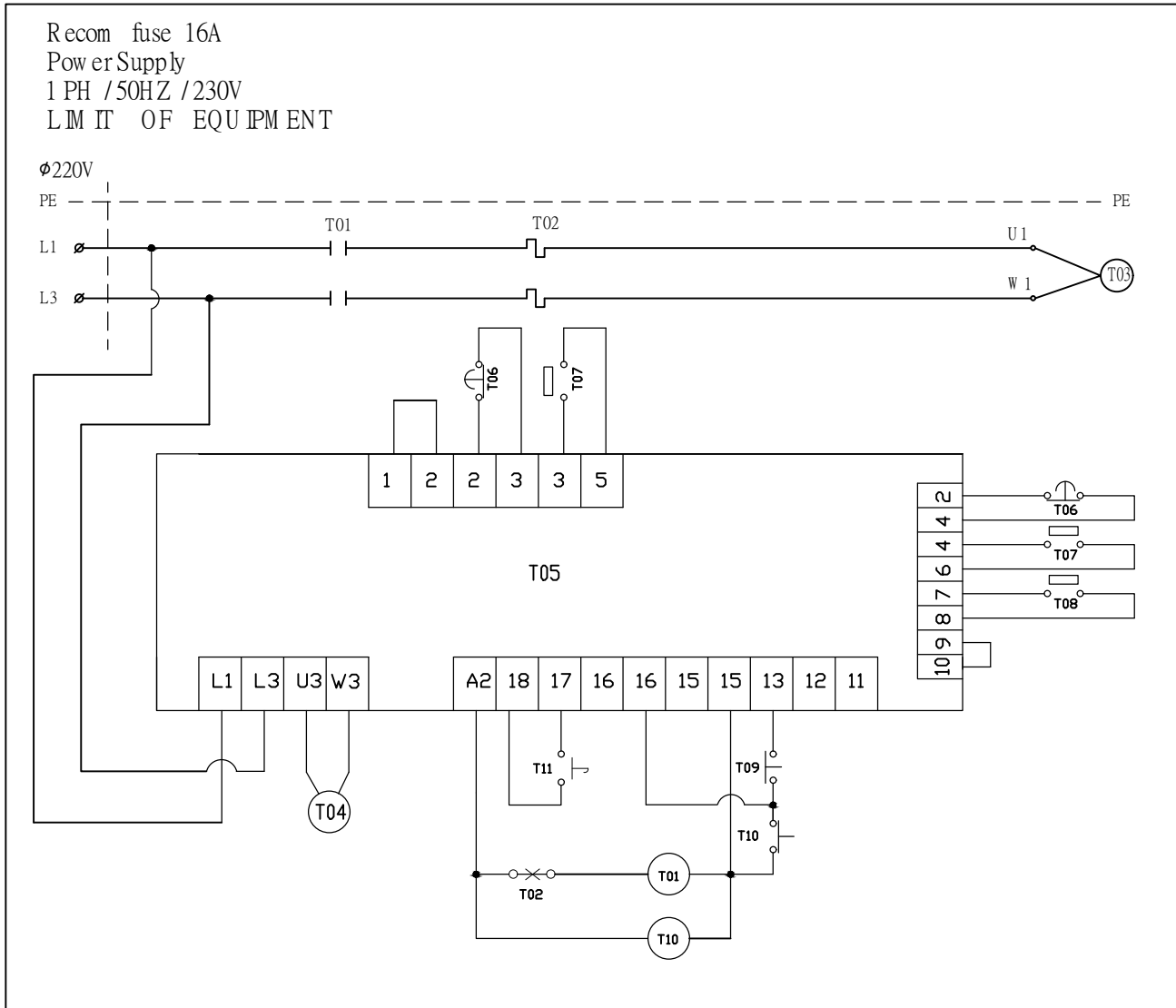

Part No	Name	Description	Producer	Type	Mark
T01	MS1	MS	SH IHLN	S-P09	CE
T02	OL	OL	SH IHLN	TH-P09PPS	CE
T03	M1	SAW MOTOR	GEORGE	1100W /750W	CE
T04	M2	PUMP MOTOR	GEORGE	100W	CE
T05	PCB	CIRCUIT BOARD	GEORGE	J88	CE
T06	EMS	EMERGENCY STOP	NHD	NPB22-R02R	CE
T07	SAFE MICRO	MICRO SWITCH	SRAKE	SRK-D2N	CE
T08	DOWN MICRO	MICRO SWITCH	GEORGE	CY-101	CE
T09	OFF	O SWITCH	NHD	NPB22-F01B	CE
T10	ON	I SWITCH	NHD	NLB22-E10W A	CE
T11	COOL	COOL SWITCH	NHD	NSS22-L210B	CE